

Interior Wayfinding Sign Program

Design Development 100%

08 October, 2015

**Weidner**CA

Signage and Graphics  
to Brand the Built Environment®









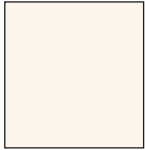
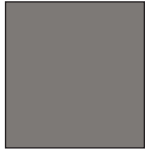

In collaboration with:

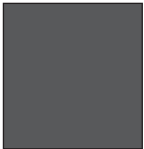

ABCDEFGHIJKLMNOPQRSTUVWXYZ  
 1234567890 abcdefghijklmnopqrstuvwxyz  
 GT Walsheim Regular

ABCDEFGHIJKLMNOPQRSTUVWXYZ  
 1234567890 abcdefghijklmnopqrstuvwxyz  
 Avenir Next Condensed

Fonts

				
			P1 Sherwin William SW6148 Wool Skein	P13 Sherwin Williams SW7019 Gauntley Grey
				
P53 3M Tomato Red	P56 3M Royal Purple	P57 3M Olympic Blue	P58 3M Sunflower	P59 3M Bright Orange
				
	M1 ROWMARK Grey	M2 ROWMARK Sand	V1 Avery Dark Gray	V3 3M Eggshell

Colors

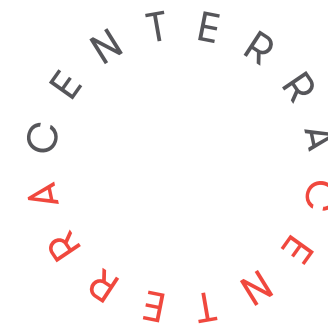

Identity

Table Of Contents

Description	Page
EID Elevator ID	1.0
AG Amenity Guidelines	2.0
CD Corridor Wayfinding	3.0
R5 Storage Room ID	4.0

Sign Location Plans

5001 24th Street  
 Sacramento, CA 95822  
**916-452-8000**

WeidnerCA.com

CA License No. 559090  
 NV License No. 0040109

Consulting Designers



creative@rossluthin.com  
**707.573.7359**

**Project:**  
 Centerra  
 77 North Almaden Avenue  
 San Jose, CA 95113

**Client:**  
 Simeon Commercial Properties

- Planning
- Schematic Design
- 10.08.15  Design Devel. 100%
- City Submittal
- Design Intent

Scale  
 N/A

DIGITAL RENDERINGS, COLORS, AND FINISHES ARE SHOWN FOR ILLUSTRATIVE PURPOSES ONLY. COLORS AND FINISHES ARE NOT TO BE USED AS SAMPLES OF ACTUAL PAINT AND/OR MATERIAL FINISHES. ACTUAL SIGNS WILL CONFORM TO SCALE DIMENSIONS.

©2015 WEIDNER.CA AND ROSS/LUTHIN CREATIVE. NO PART OF THE ABOVE DRAWING(S) DESIGN, ARRANGEMENTS OR IDEAS HEREON SHALL BE DUPLICATED FOR ANY PURPOSE WHATSOEVER WITHOUT THE EXPRESSED WRITTEN CONSENT OF WEIDNER.CA AND ROSS/LUTHIN CREATIVE.

Interior Contents,  
 Colors & Fonts



P56 3M Royal Purple    P53 3M Tomato Red    P57 3M Olympic Blue    P58 3M Sunflower    P59 3M Bright Orange

Messages  
1"=1'-0"

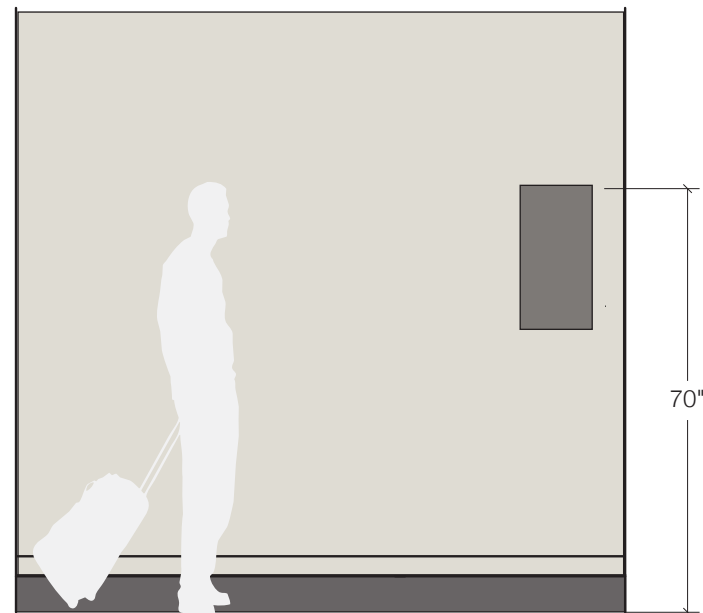

Placement Elevation  
3/8"=1'-0"

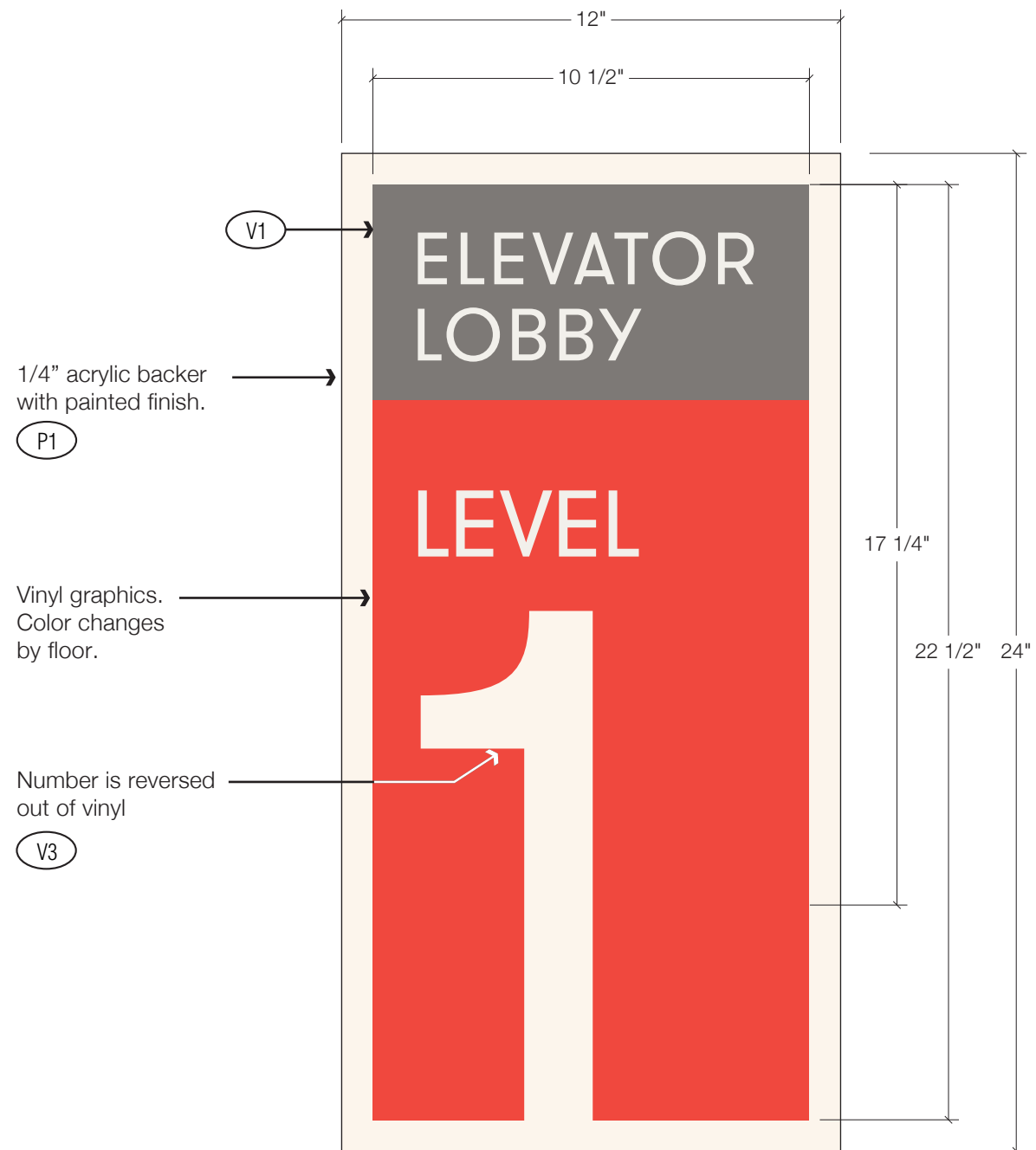

Front

Plaque  
3"=1'-0"



**Project:**

Centerra  
77 North Almaden Avenue  
San Jose, CA 95113

**Client:**

Simeon Commercial Properties

- Planning
- Schematic Design
- 10.08.15  Design Devel. 100%
- City Submittal
- Design Intent

**Scale**

3"=1'-0" UON

DIGITAL RENDERINGS, COLORS, AND FINISHES ARE SHOWN FOR ILLUSTRATIVE PURPOSES ONLY. COLORS AND FINISHES ARE NOT TO BE USED AS SAMPLES OF ACTUAL PAINT AND/OR MATERIAL FINISHES. ACTUAL SIGNS WILL CONFORM TO SCALE DIMENSIONS.

©2015 WEIDNER.CA AND ROSS/LUTHIN CREATIVE. NO PART OF THE ABOVE DRAWING(S) DESIGN, ARRANGEMENTS OR IDEAS HEREON SHALL BE DUPLICATED FOR ANY PURPOSE WHATSOEVER WITHOUT THE EXPRESSED WRITTEN CONSENT OF WEIDNER.CA AND ROSS/LUTHIN CREATIVE.

**EID**

Elevator ID

5001 24th Street  
Sacramento, CA 95822  
**916-452-8000**

WeidnerCA.com

CA License No. 559090  
NV License No. 0040109

Consulting Designers



creative@rossluthin.com  
**707.573.7359**

**Project:**  
Centerra  
77 North Almaden Avenue  
San Jose, CA 95113

**Client:**  
Simeon Commercial Properties

- Planning
- Schematic Design
- 10.08.15  Design Devel. 100%
- City Submittal
- Design Intent

Scale  
3"=1'-0" UON

DIGITAL RENDERINGS, COLORS, AND FINISHES ARE SHOWN FOR ILLUSTRATIVE PURPOSES ONLY. COLORS AND FINISHES ARE NOT TO BE USED AS SAMPLES OF ACTUAL PAINT AND/OR MATERIAL FINISHES. ACTUAL SIGNS WILL CONFORM TO SCALE DIMENSIONS.

©2015 WEIDNER.CA AND ROSS/LUTHIN CREATIVE. NO PART OF THE ABOVE DRAWING(S) DESIGN, ARRANGEMENTS OR IDEAS HEREON SHALL BE DUPLICATED FOR ANY PURPOSE WHATSOEVER WITHOUT THE EXPRESSED WRITTEN CONSENT OF WEIDNER.CA AND ROSS/LUTHIN CREATIVE.

**AG**  
Amenity Guidelines

**2.0**

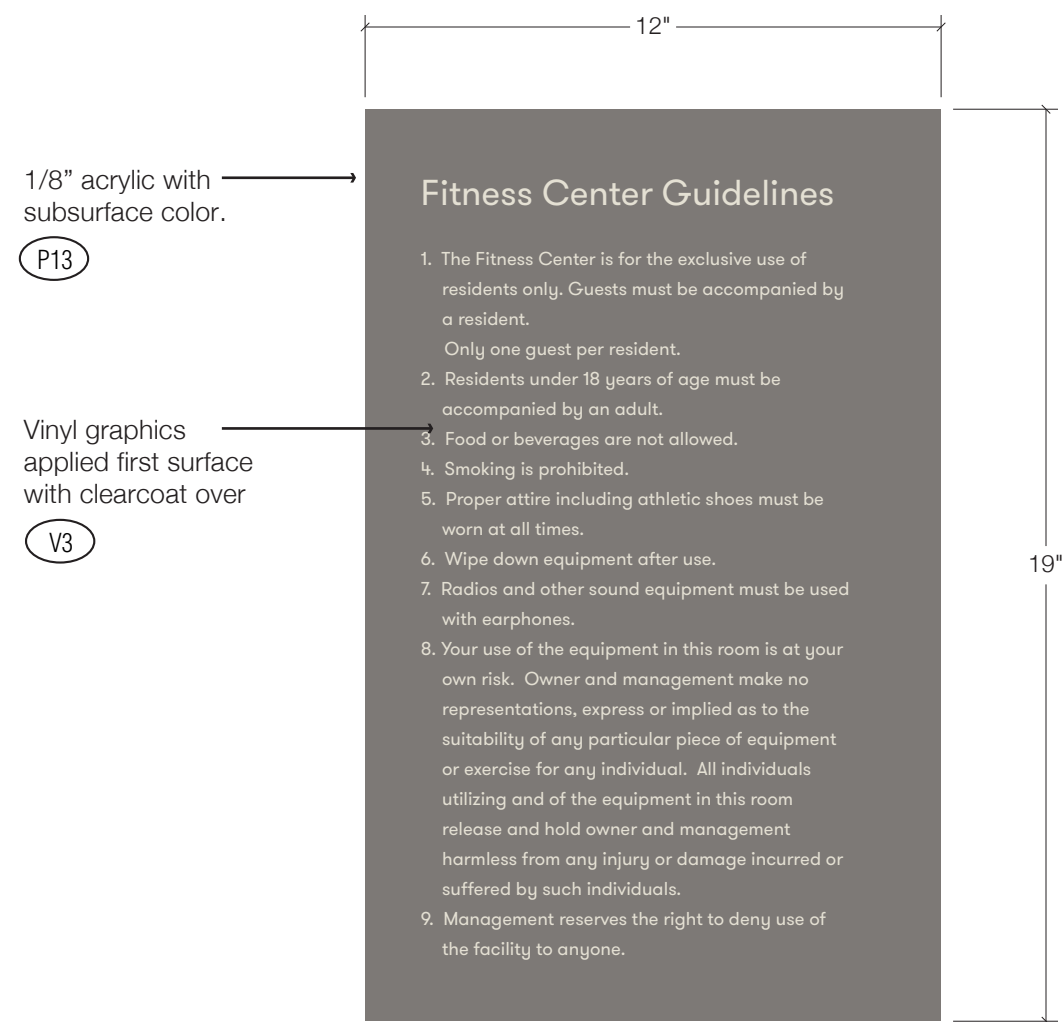

Face

Side



- Planning
- Schematic Design
- 10.08.15  Design Devel. 100%
- City Submittal
- Design Intent

Scale  
3"=1'-0" UON

DIGITAL RENDERINGS, COLORS, AND FINISHES ARE SHOWN FOR ILLUSTRATIVE PURPOSES ONLY. COLORS AND FINISHES ARE NOT TO BE USED AS SAMPLES OF ACTUAL PAINT AND/OR MATERIAL FINISHES. ACTUAL SIGNS WILL CONFORM TO SCALE DIMENSIONS.

©2015 WEIDNER.CA AND ROSS/LUTHIN CREATIVE NO PART OF THE ABOVE DRAWING(S) DESIGN, ARRANGEMENTS OR IDEAS HEREON SHALL BE DUPLICATED FOR ANY PURPOSE WHATSOEVER WITHOUT THE EXPRESSED WRITTEN CONSENT OF WEIDNER.CA AND ROSS/LUTHIN CREATIVE.

**CD**  
Corridor Directional

**3.0**

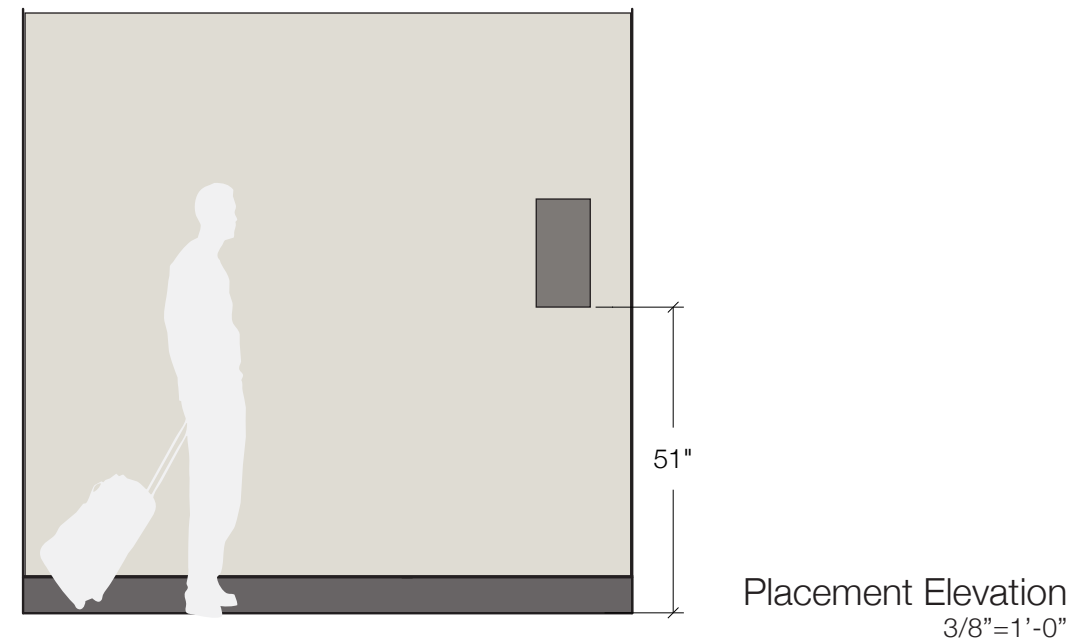
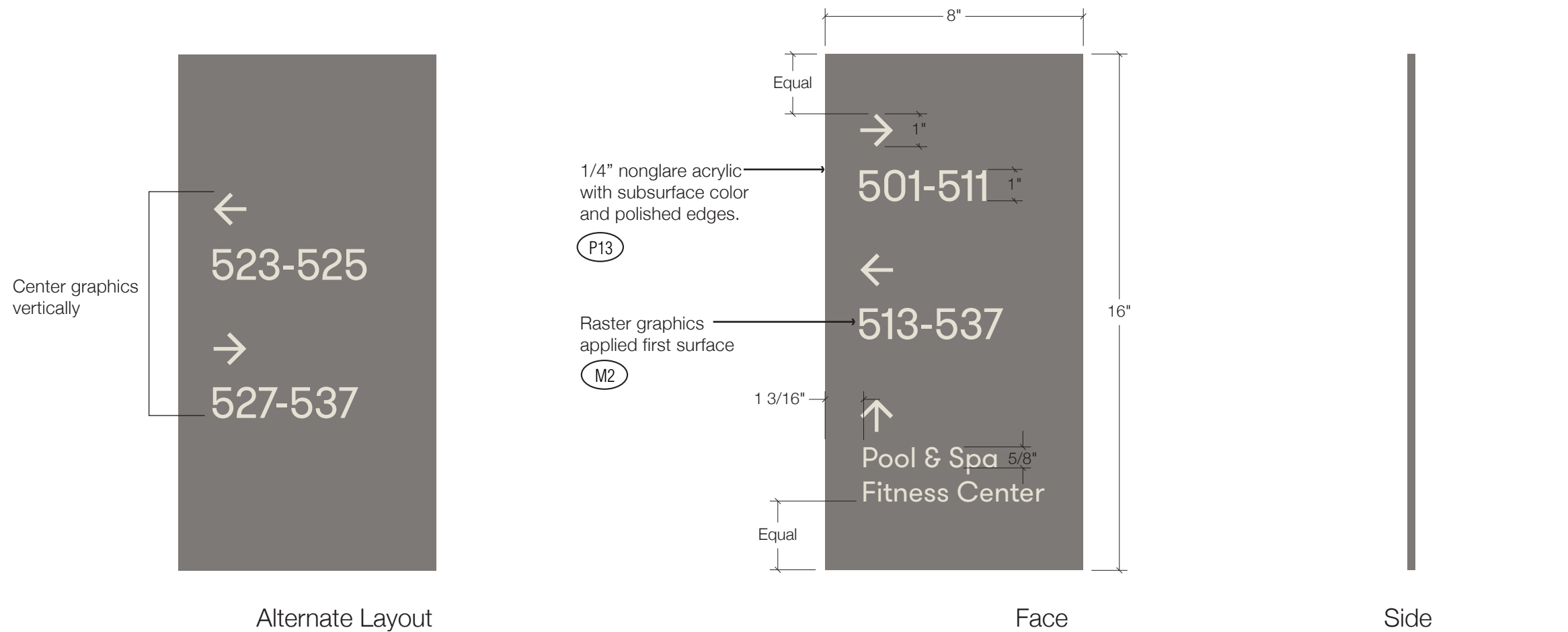

5001 24th Street  
Sacramento, CA 95822  
**916-452-8000**

WeidnerCA.com

CA License No. 559090  
NV License No. 0040109

Consulting Designers



creative@rossluthin.com  
**707.573.7359**

**Project:**  
Centerra  
77 North Almaden Avenue  
San Jose, CA 95113

**Client:**  
Simeon Commercial Properties

- Planning
- Schematic Design
- 10.08.15  Design Devel. 100%
- City Submittal
- Design Intent

Scale  
6"=1'-0" UON

DIGITAL RENDERINGS, COLORS, AND FINISHES ARE SHOWN FOR ILLUSTRATIVE PURPOSES ONLY. COLORS AND FINISHES ARE NOT TO BE USED AS SAMPLES OF ACTUAL PAINT AND/OR MATERIAL FINISHES. ACTUAL SIGNS WILL CONFORM TO SCALE DIMENSIONS.

©2015 WEIDNER.CA AND ROSS/LUTHIN CREATIVE. NO PART OF THE ABOVE DRAWING(S) DESIGN, ARRANGEMENTS OR IDEAS HEREON SHALL BE DUPLICATED FOR ANY PURPOSE WHATSOEVER WITHOUT THE EXPRESSED WRITTEN CONSENT OF WEIDNER.CA AND ROSS/LUTHIN CREATIVE.

**R5**  
Storage Room ID

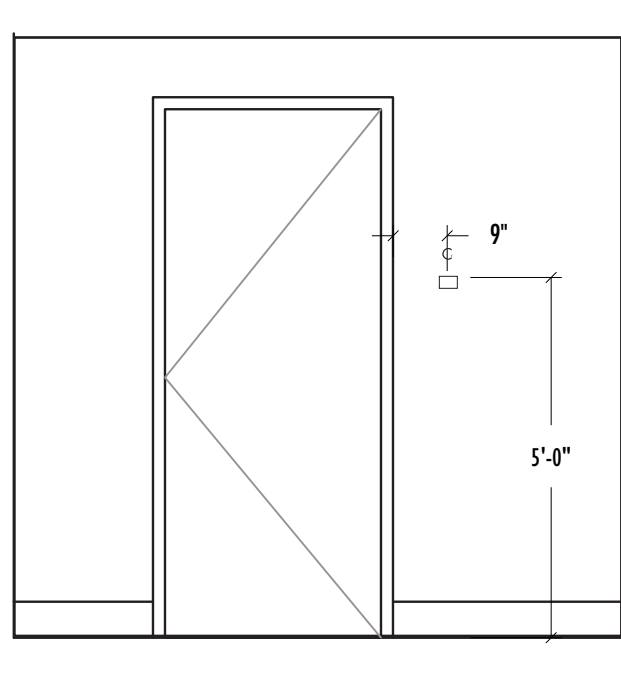

Placement Elevation  
3/8"=1'-0"

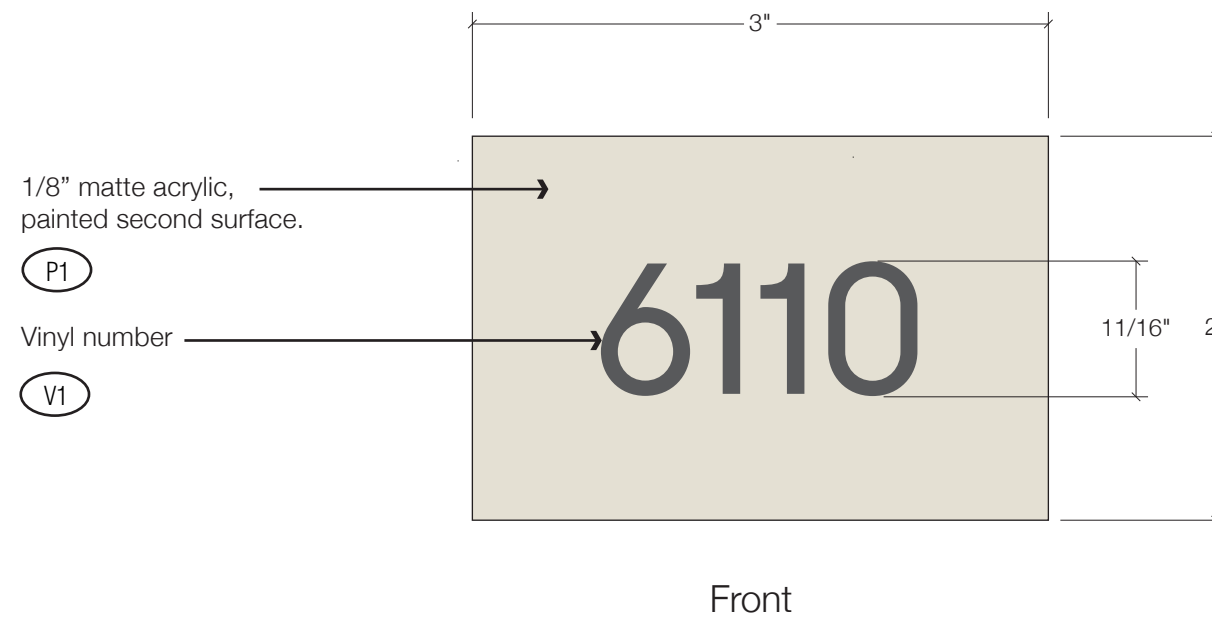

Details  
Full Size